

For OCR

**GENERAL CERTIFICATE OF SECONDARY EDUCATION
MATHEMATICS**

Higher Paper 3A

Time: 2 hours

Candidates answer on the question paper.

Additional materials: Geometrical instruments
Tracing paper (optional)

INSTRUCTIONS AND INFORMATION FOR CANDIDATES

- Do not write on this question paper – use blank paper and the answer sheets provided.
- Answer **all** the questions.
- Read each question carefully.
- Show all your working. Marks may be given for working even if you get the answer wrong.
- The total number of marks for this paper is 100.



WARNING You are not allowed to use a calculator in this paper.

FORMULAE

Volume of prism = (area of cross-section) \times length

In any triangle *ABC*

Sine rule $\frac{a}{\sin A} = \frac{b}{\sin B} = \frac{c}{\sin C}$

Cosine rule $a^2 = b^2 + c^2 - 2bc \cos A$

Area of triangle = $\frac{1}{2} ab \sin C$

Volume of sphere = $\frac{4}{3} \pi r^3$

Surface area of sphere = $4\pi r^2$

Volume of cone = $\frac{1}{3} \pi r^2 h$

Curved surface area of cone = $\pi r l$

The Quadratic Equation

The solutions of $ax^2 + bx + c = 0$,

where $a \neq 0$, are given by

$$x = \frac{-b \pm \sqrt{(b^2 - 4ac)}}{2a}$$

*Churchill
Maths*



Written by Shaun Armstrong

Only to be copied for use in the purchaser's school or college

1

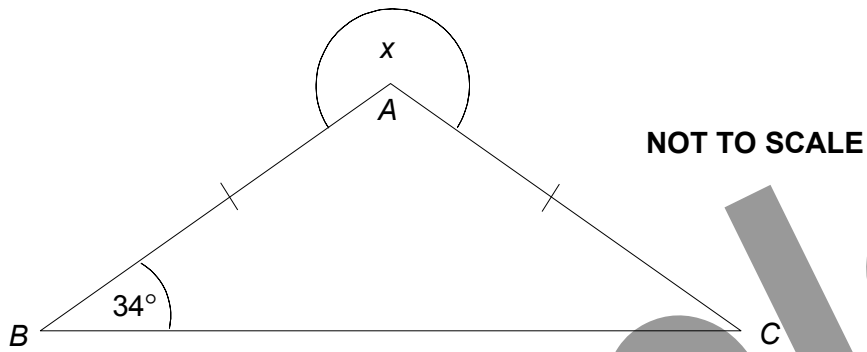

In the diagram, $AB = AC$ and angle $ABC = 34^\circ$.

Find the size of the angle marked x .

[3]

2 (a) Express 56 as the product of its prime factors.

[2]

(b) Find the Highest Common Factor (HCF) of 56 and 84.

[2]

3 The table gives information about the number of bedrooms in 720 houses.

Number of Bedrooms	Frequency
1	100
2	320
3	240
4	60

Draw an accurate pie chart on the answer sheets to show this information.

[4]

4 (a) On the grid on the answer sheets, draw the graph of $y = 2x - 3$

[3]

(b) Use your graph to solve the equation $2x - 3 = 1.4$

[1]

5 Tariq's bicycle has three gears.
The numbers of teeth on the gears are in the ratio $5 : 6 : 7$
In total there are 36 teeth on the gears.

(a) Work out how many teeth are on the middle gear.

[3]

Tariq cycles 5 kilometres in 20 minutes.

(b) Work out his average speed in kilometres per hour.

[2]

6



NOT TO SCALE

The bearing of Y from X is 115° .

Work out the bearing of X from Y .

[2]

7 A set of mathematical instruments costs £2.80 plus $17\frac{1}{2}\%$ VAT.

(a) Calculate the total cost of the set of instruments.

[3]

A school wants to buy 470 sets of mathematical instruments.
They buy them in boxes of 40

(b) Work out the number of boxes the school should buy.

[2]

8 The table shows the age in days and the heights in centimetres of eight plants.

Age (days)	36	115	68	23	101	65	38	91
Height (cm)	11.5	20.2	16.7	7.6	19.3	12.8	10.5	16.3

The first six pairs of values have been plotted on the scatter graph on the answer sheets.

(a) Plot the last two pairs of values on the scatter graph.

[1]

(b) Describe the **correlation** between the age and height of the plants.

[1]

(c) (i) Use your graph to estimate the age of another plant of the same type when it reached a height of 15 cm.

[2]

(ii) Explain why it might not be sensible to use your graph to estimate the age of a plant of the same type that is 24 cm tall.

[1]

- 9 A supermarket records the weight (w kg) of loose potatoes bought by 100 customers. The results are shown in the table.

Weight of potatoes (w kg)	Frequency
$0.5 < w \leq 1.0$	6
$1.0 < w \leq 1.5$	21
$1.5 < w \leq 2.0$	34
$2.0 < w \leq 2.5$	23
$2.5 < w \leq 3.0$	16

- (a) What percentage of these customers bought more than 2.5 kg of potatoes? [1]
- (b) On the grid on the answer sheets, draw a frequency diagram to represent the data in the table. [2]
- 10 Triangle ABC is shown on the answer sheets.
Shade the region inside the triangle which is nearer to point A than point C and less than 5 cm from the point C . [4]
- 11 In the following expressions L , W and H are all lengths. Decide, for each of the expressions, whether it could represent a length, an area or a volume.
- (a) $L + W$ [1]
- (b) LH^2 [1]
- (c) $L(W + H)$ [1]
- 12 (a) Simplify $(2a)^2$ [1]
- (b) Simplify $\frac{x^5 \times x^2}{x^3}$ [1]
- (c) Expand $y^2(3y - 2)$ [1]
- (d) Solve $5p + 9 = p - 3$ [3]
- (e) Show that $x^2 - 8x + 19$ can be written in the form $(x + a)^2 + b$ for all values of x . State the value of a and the value of b . [3]

13

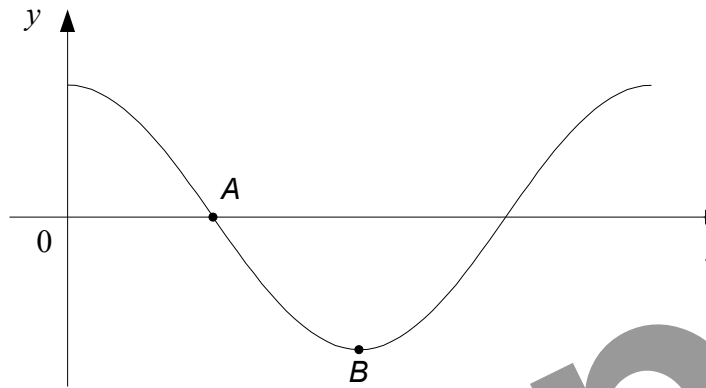

The diagram shows a sketch of part of the graph of $y = \cos x^\circ$.

(a) Write down the coordinates of

(i) A,

[1]

(ii) B.

[1]

(b) On the copy of the diagram above on the answer sheets, sketch the graph of $y = \cos 2x^\circ$.

[2]

14

$$P = 2\pi r + 5r - l$$

Rearrange the formula to make r the subject.

[3]

15 The ages of three sisters are x years, x^2 years and $(3x - 2)$ years.

The total of the ages of the three sisters is 30 years.

(a) Show that $x^2 + 4x - 32 = 0$

[2]

(b) Find the age of the oldest of the three sisters.

[3]

16

(a) Work out an estimate for the value of $\frac{916 \times 28.45}{(2.96)^2}$

[3]

(b) Write down the value of $9^{-\frac{1}{2}}$

[1]

(c) Rationalise the denominator of $\frac{18}{\sqrt{3}}$ and simplify your answer.

[2]

17 Prove algebraically that the sum of three consecutive even numbers is always a multiple of 6.

[3]

18

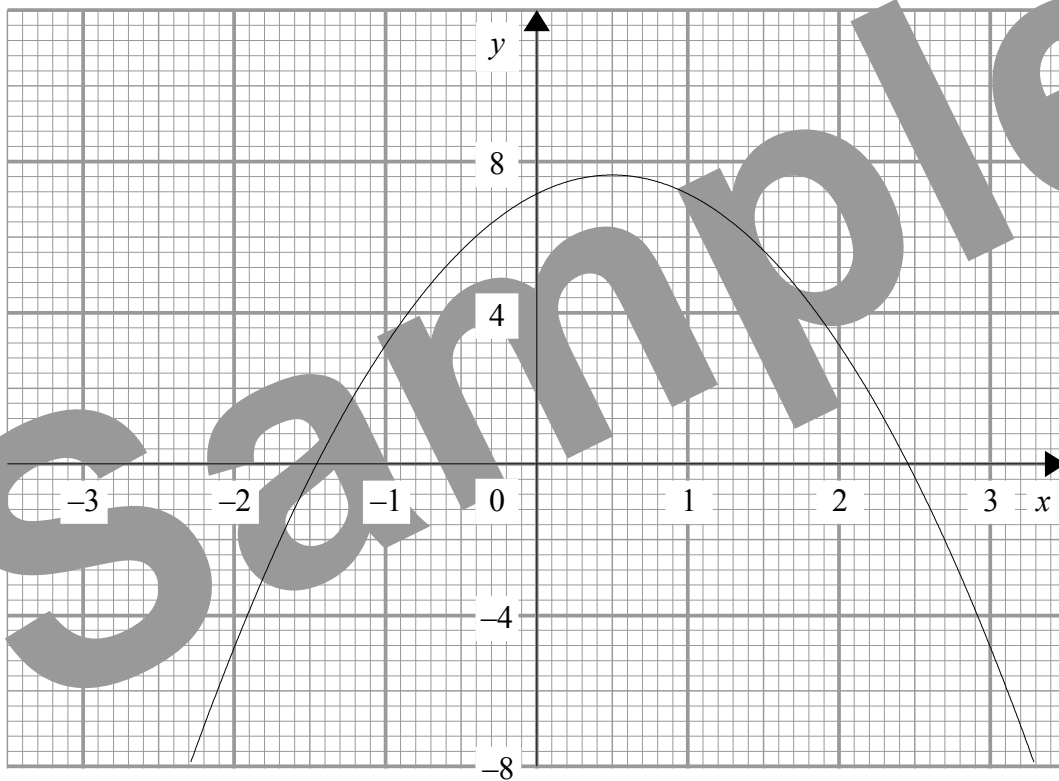

The diagram shows the graph of $y = 7 + 2x - 2x^2$

(a) Use the graph to estimate the solutions to the equation

$$7 + 2x - 2x^2 = 0$$

[1]

(b) Explain how, using the graph, you can tell that there are no solutions to the equation

$$2x - 2x^2 = 1$$

[2]

- 19 Jenny is marking Question 1 on a set of examination papers.
The question has two parts and for each part, an answer is either correct or incorrect.

On a paper, the probability that she will mark part (i) correct is $\frac{3}{4}$

If she marks part (i) correct, the probability that she will mark part (ii) correct is $\frac{4}{5}$

If she marks part (i) incorrect, the probability that she will mark part (ii) correct is $\frac{1}{3}$

Jenny marks one paper.

- (a) Complete the tree diagram on the answer sheets. [3]

- (b) Work out the probability that she marks both parts correct. [2]

One evening, Jenny marks 180 papers.

- (c) Work out an estimate for the number of papers on which she marks at least one part correct. [4]

20

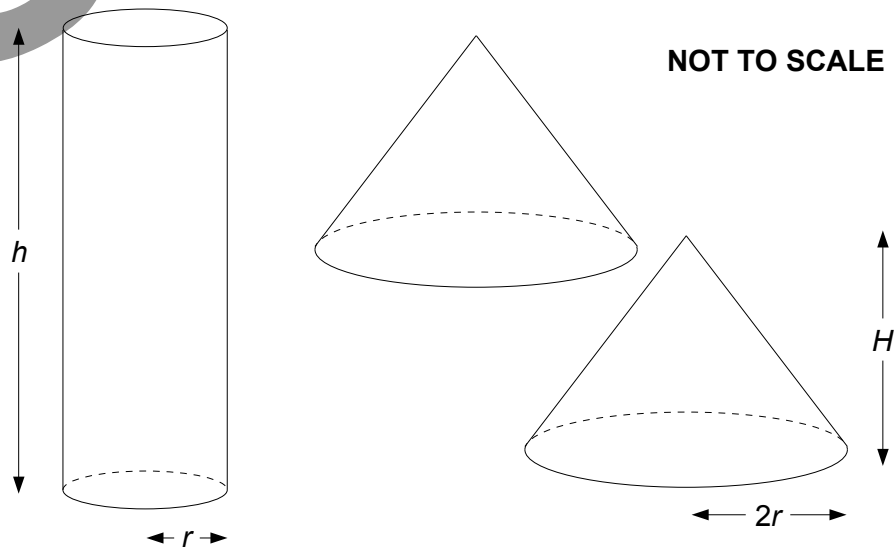

Some plasticine is used to make a solid cylinder of base radius r cm and height h cm.

The plasticine is then split in half and used to make two identical cones.
Each cone has base radius $2r$ cm and height H cm.

Express H in terms of h .
Give your answer in its simplest form.

[4]

21

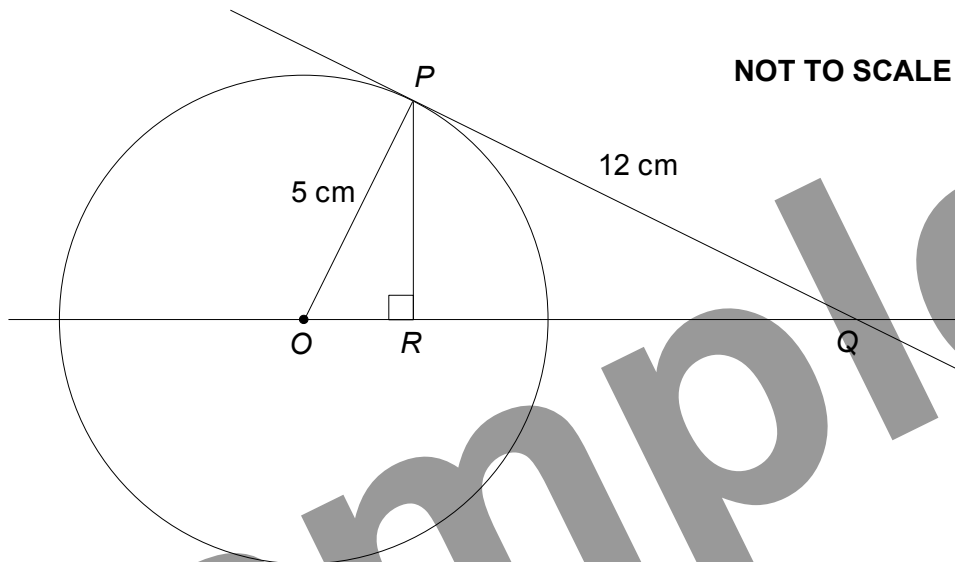

P is a point on a circle, centre O .
 The line PQ is the tangent to the circle at P .
 R is the point on OQ such that $\angle ORP = 90^\circ$.

(a) Prove that triangle OPR and triangle OPQ are similar.

[3]

$OP = 5$ cm. $PQ = 12$ cm.

(b) Find the exact length of OR .

[4]

22

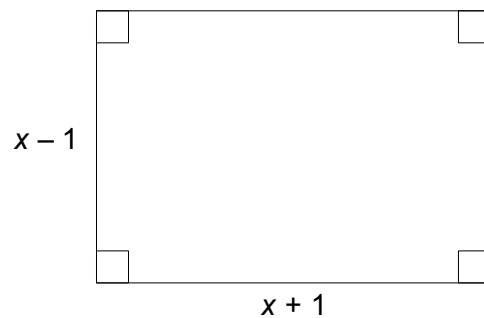

The diagram shows a rectangle measuring $(x - 1)$ cm by $(x + 1)$ cm.
 The diagonals of the rectangle are each 10 cm long.

Find the area of the rectangle.

[5]

For OCR

Name

Answer Sheets for Higher Tier, Paper 3A

3

Sample

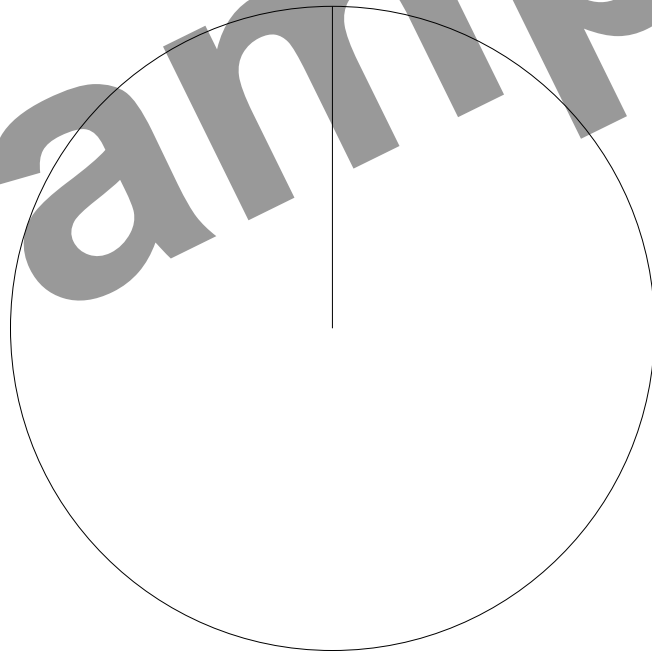

4 (a)

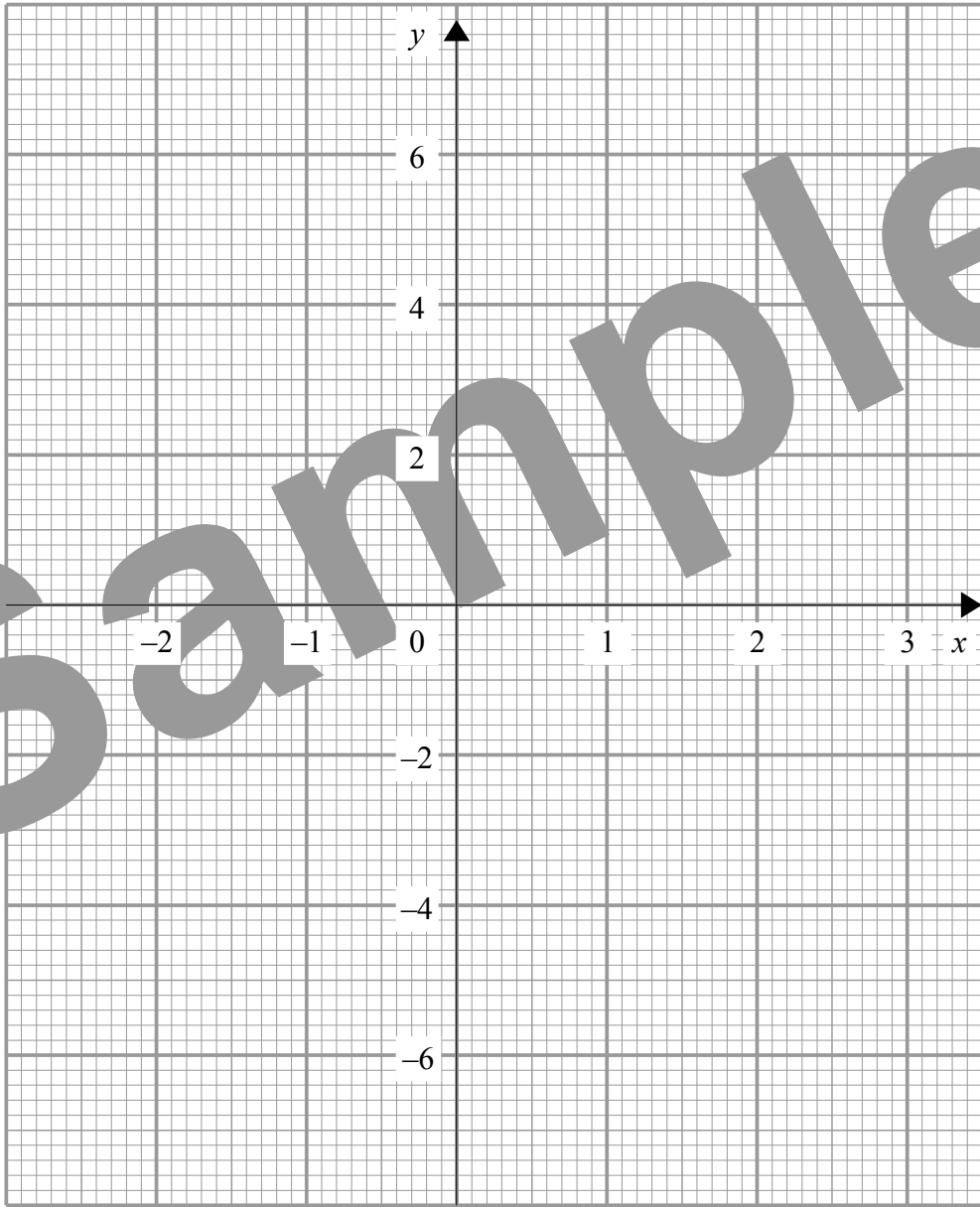

8

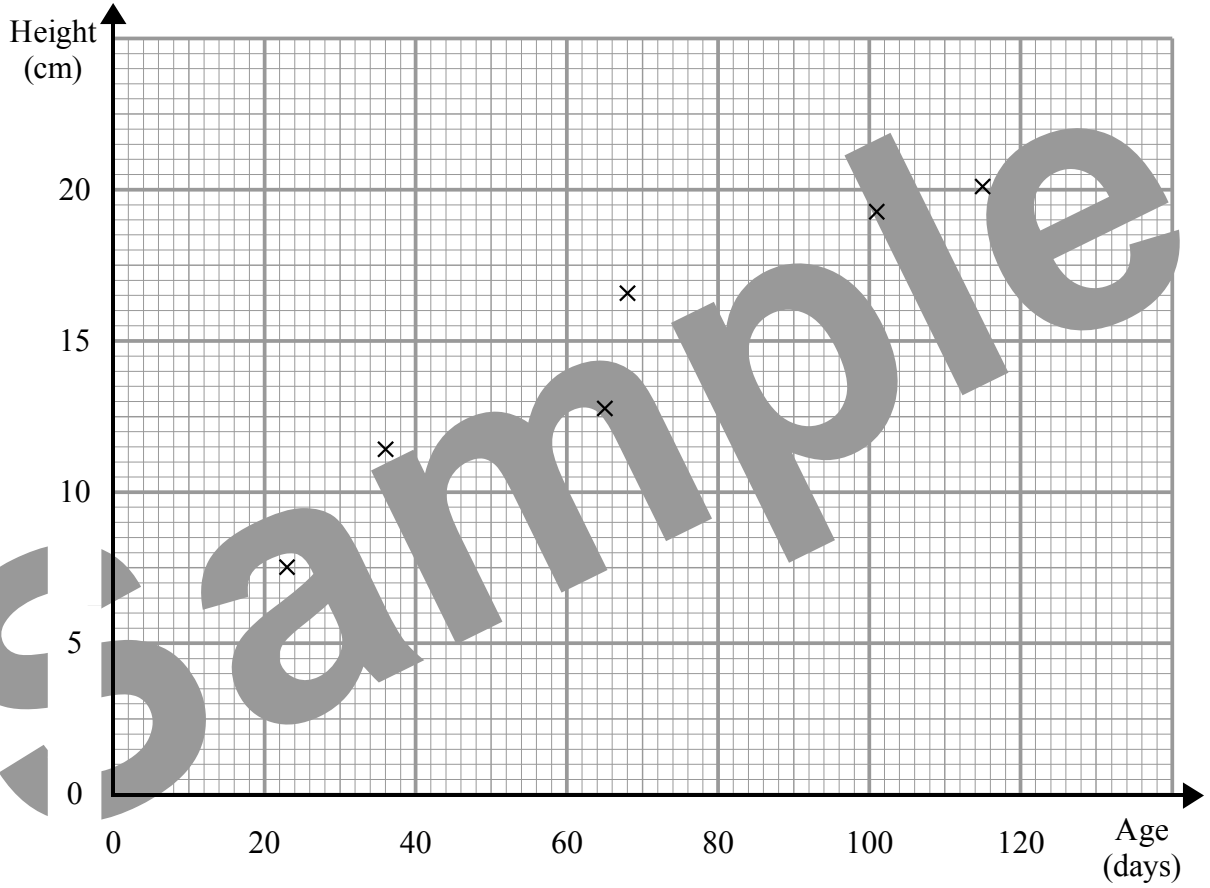

9 (b)

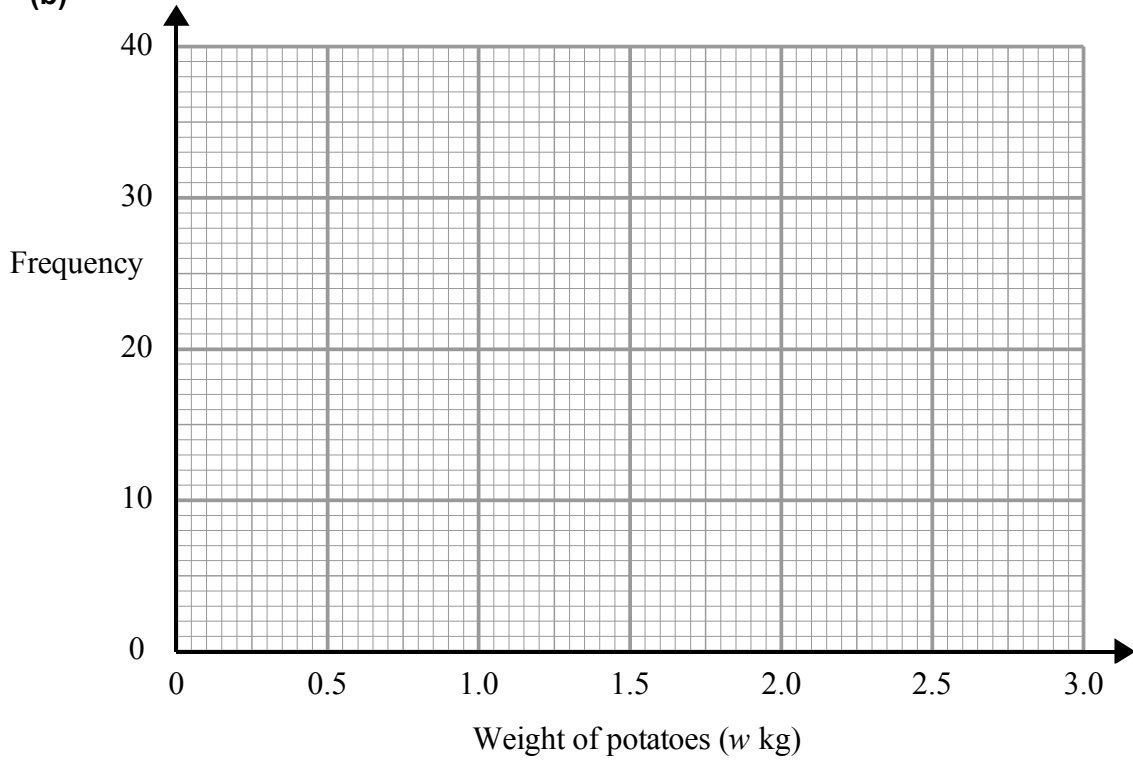

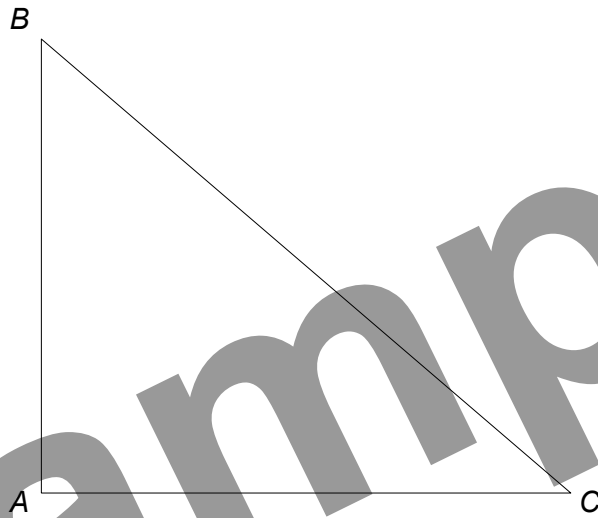

13 (b)

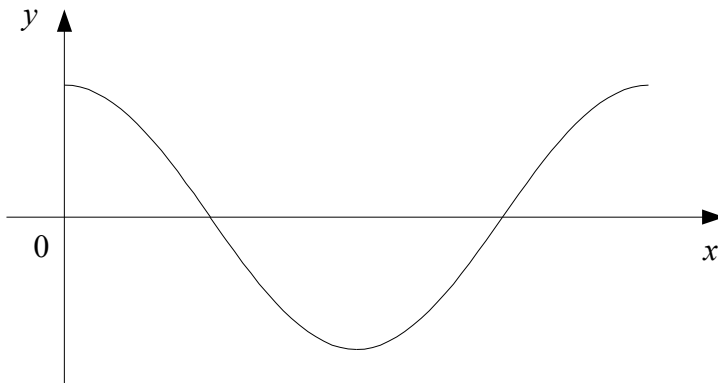

19 (a)

part (i)

part (ii)

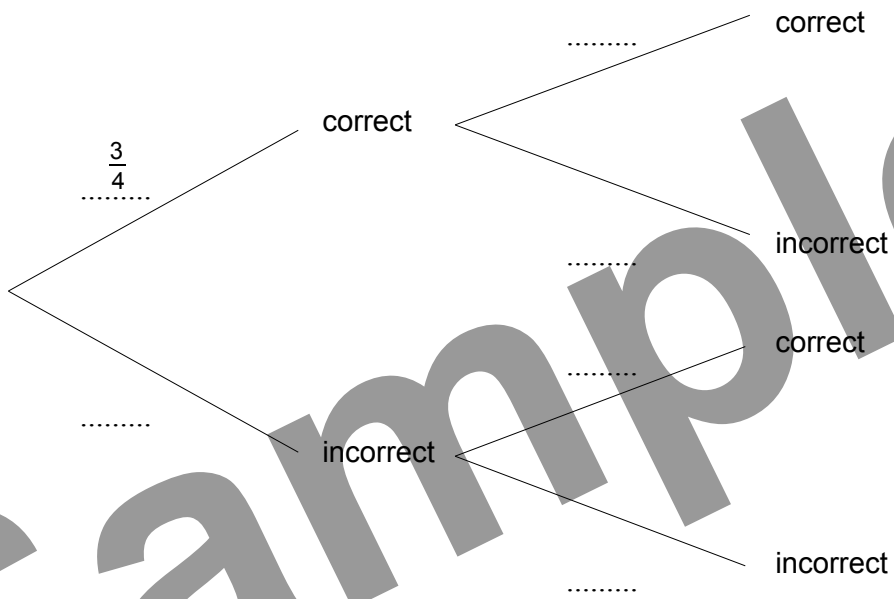

Sample